

JANUARY 2026

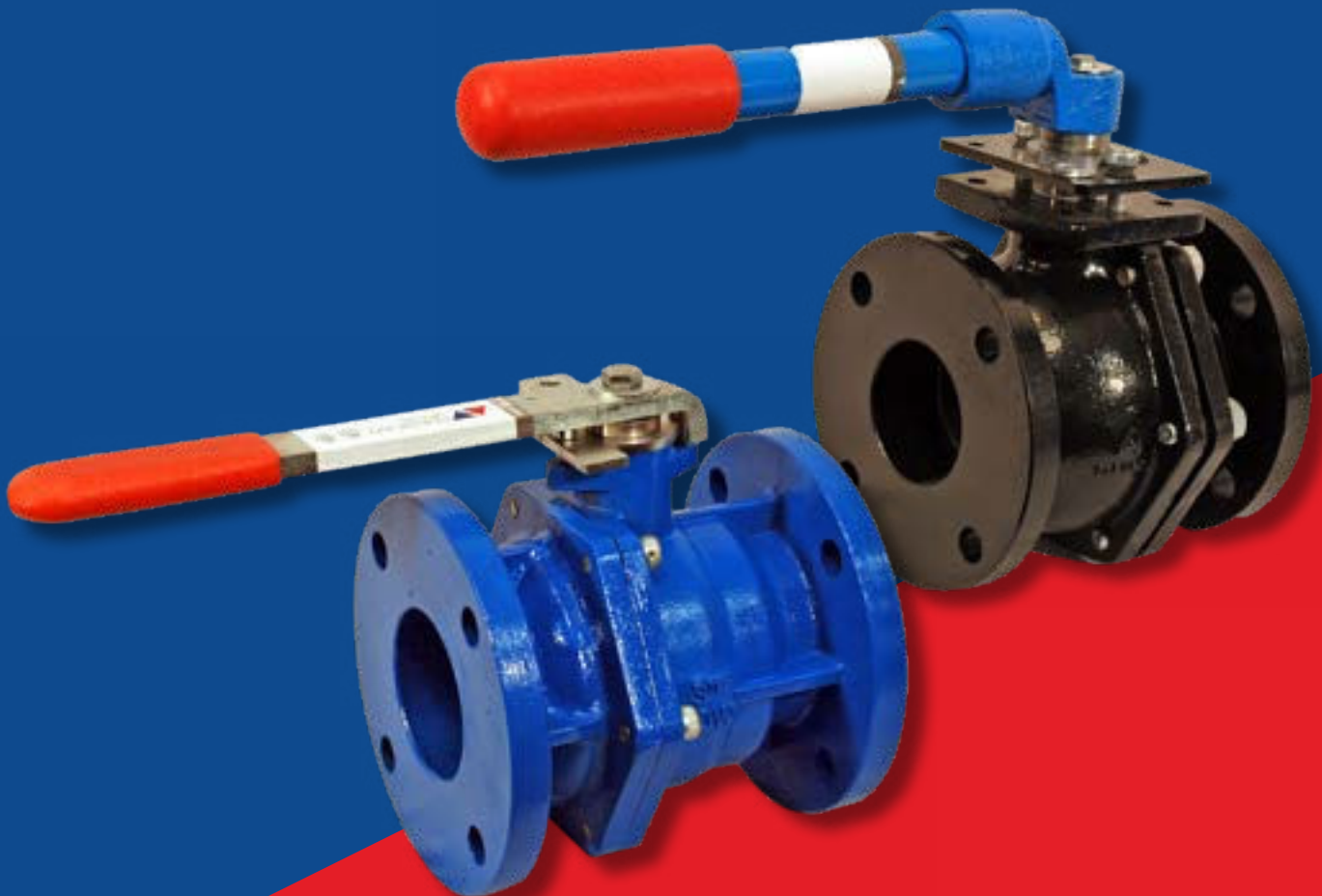

4000 SERIES

BALL VALVES





Innovative Solutions That Solve Everyday Water Challenges

American Valve has been known for high-quality valves used in plumbing, HVAC, and industrial applications for more than 100 years. We are known throughout world as the leader in ball valves, plumbing valves, thermoplastic valves, and water treatment components.

Our products are engineered to solve flow control challenges in a broad range of applications, and are designed to provide years of reliable service.

OUR VALVES

American Valve's 4000 Series™ is a solution without compromise for facility, factory, and municipal managers. Featuring a patented, corrosion-resistant PFA-fused solid ball, the 4000 Series is more durable, less susceptible to buildup, and longer-lasting than any ordinary ball valve.

Our design provides maximum flow rate free from obstruction and is the ideal alternative to gate, butterfly, and eccentric plug valves. Seats are protected from wear, and automation is a breeze with low operating torque and an ISO standard mounting pad.





Golf courses, agriculture, public parks, sports facilities



Compressed air, DWV systems, Pump isolation, Water main shutoff



Booster pumps, drain lines, hydronic & potable systems, data centers

HYDRONICS
WATER TREATMENT
WASTEWATER
IRRIGATION
GENERAL INDUSTRIAL
HVAC
POTABLE WATER



Mining, biodiesel & ethanol production, storage, & distribution, petroleum blending, storage, & loading, food processing, plant utilities, power plants



Digester aerators, sludge processing, methane gas gathering, storage, & distribution, force mains, lift stations, chemical feed lines, drain lines

The 4000 Series Flanged Ball Valve replaces **any** traditional gate valve or eccentric plug valve. Featuring a corrosion-resistant PFA-fused solid metal ball, the 4000 is more durable, less susceptible to accumulation of buildup, and longer-lasting than an ordinary unprotected ball.

With the same end-to-end dimensions, a full port design for maximum flow, and a versatile design that simplifies retrofits and automation, the American Valve 4000 pairs quarter-turn convenience with dramatically lower torque—making it the leader in ball valve technology.

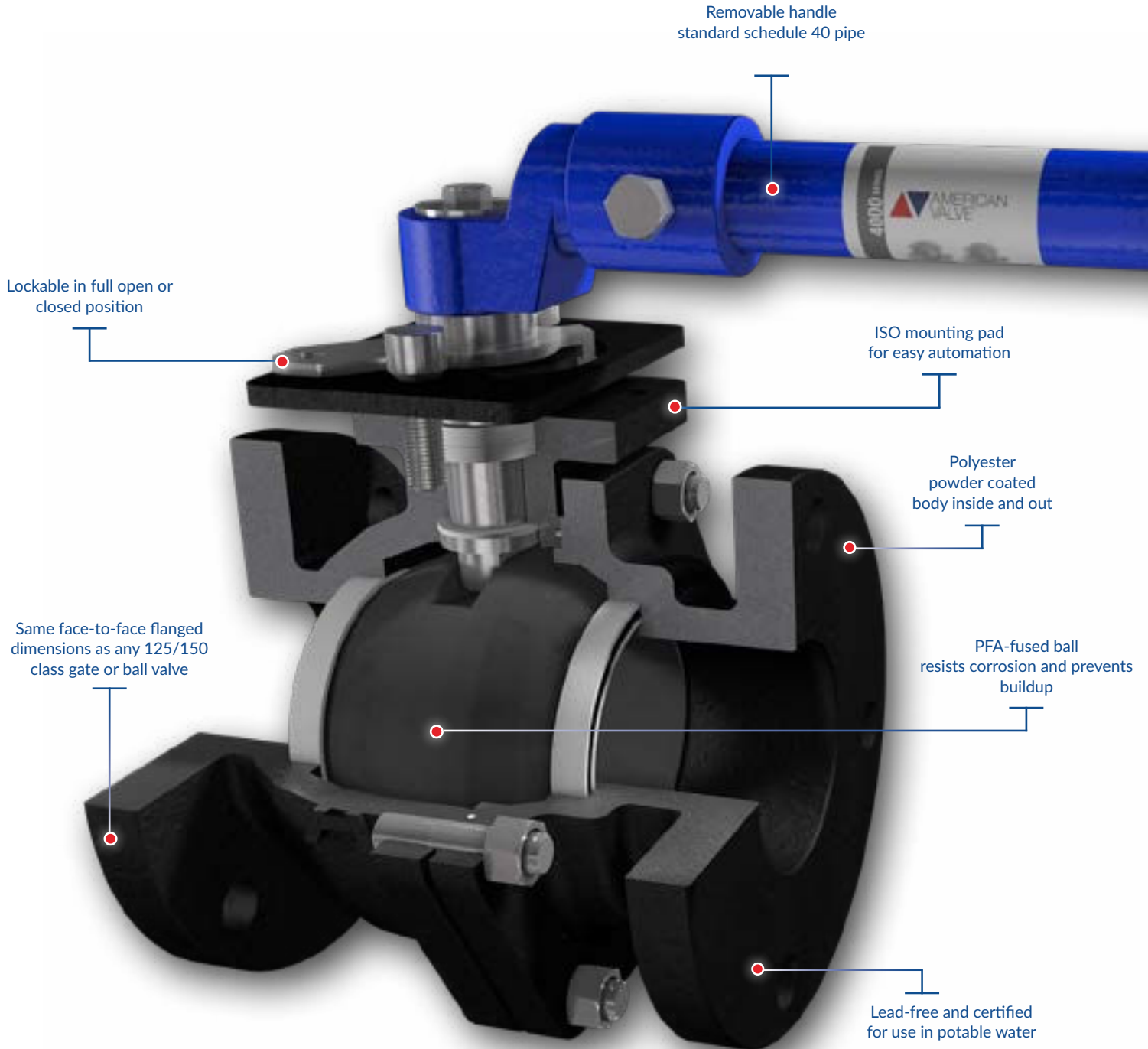

INSIDE THE AMERICAN VALVE PFA*-FUSED BALL

- More corrosion-resistant than balls with unprotected metal surfaces.
- Inhibits the buildup of lime, calcium, sludge, etc. that accumulates on a ball's surface and prevents premature failure of the valve seats.
- The lubricity of the PFA-fused ball allows for lower torque ratings in any application, eliminates ball pitting, prevents buildup, lowers torque, and stops premature valve failure.
- Since the PFA fluoropolymer is impregnated .008" into the solid metal, it doesn't wear, chip, or flake off.



PFA-FUSED BALL

- ▶ Corrosion Resistant
- ▶ Build-up Resistant
- ▶ Abrasion Resistant
- ▶ Lower Operating Torque

**PFA is an ingredient commonly branded as Teflon®
Teflon® is registered trademark of Chemours*

SPECIFICATIONS

- A126 Class B cast iron body
- PFA-fused solid ball
- Blow-out proof stainless steel stem
- Reinforced PTFE seats
- Face to face and flanged dimensions conform to ANSI Standard B16.10 which exactly match end to end dimensions of all cast iron gate valves and plug valves
- Lockable in full open or closed positions
- ISO mounting pad for easy actuation
- Adjustable Length/removable handles to fit into areas of limited space
- Full port through 6"
- Certified to meet the requirements of:
 - NSF/ANSI/CAN 61 & 372
 - MSS SP-72
 - ANSI B16.10
 - FED. SPEC. WW-V-35
 - AWWA C507-99 (Proof of Design)
- This cast iron ball valve has been engineered to replace any IBBM gate valve, all iron gate valve, or plug valve

RATINGS

- 125 psi WSP
- 200 psi WOG
- 353° F

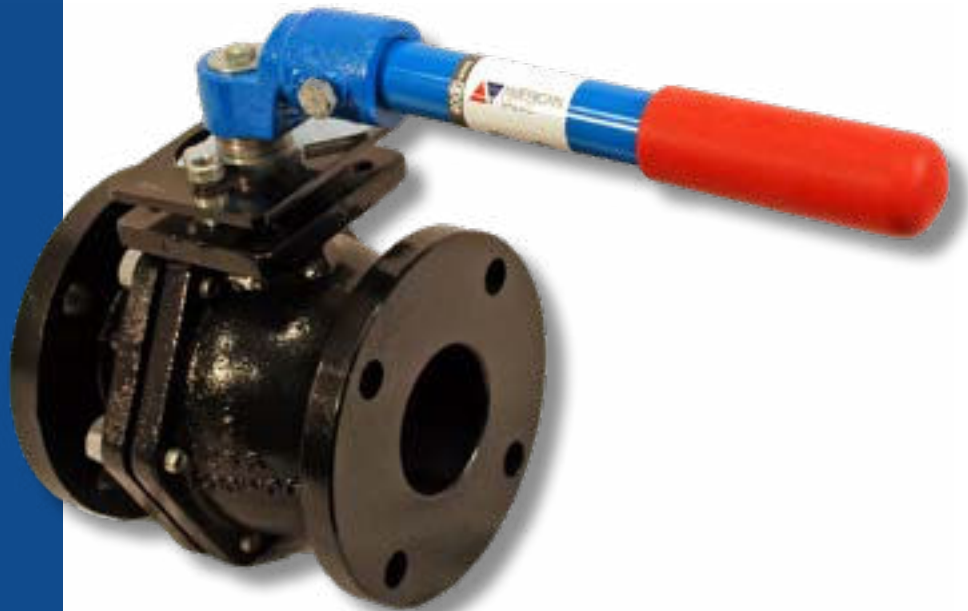

SAMPLE SPECIFICATION

Ball valves shall be of the floating-ball design providing bi-directional, tight shutoff in accordance with MSS SP-72. The valves shall be rated at 125# WSP/200# WOG. Bodies shall be of cast iron per ASTM A126 Class B, With ANSI Class 125 flat-face flanges. The interior and exterior of the body shall be powder coated and certified to NSF/ANSI/CAN standards 61 and 372. The ball shall be PFA-infused cast iron, with a stainless steel blowout-proof stem. The seats and body seals shall be PTFE. The stem seal shall be PTFE, externally adjustable chevron type. Valves shall be equipped with locking handles as standard. Valves may be equipped with 2" square operating nuts, manual gear operators, or pneumatic, electric, or hydraulic actuators. Valves shall be the 4000 Series as manufactured by American Valve, Inc. or as approved by the engineer.



Drawings
and
CAD files

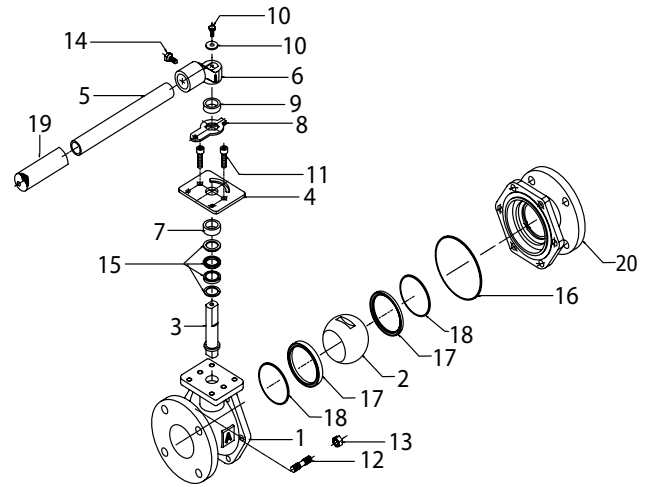

MATERIAL SPECIFICATIONS

Part	Material	ASTM
1	Body	Cast Iron ASTM A126 Class B
2	PFA Fused Ball	Cast Iron ASTM A48 Class-35
3	Stem	Stainless Steel ASTM SA 479 -10a
4	Gland Plate	Steel ASTM A53M
5	Handle	Steel ASTM A53M
6	Handle Bracket	Stainless Steel ASTM A536
7	Packing Follower	Stainless Steel ASTM SA 479 -10a
8	Stem Indicator	Steel ASTM A53M
9	Handle Bracket Spacer	Stainless Steel ASTM SA 479 -10a
10	Stem Stud	Steel ASTM A193
11	Gland Stud	Steel ASTM A53M
12	Body Stud	Steel ASTM A53M
13	Body Nut	Steel ASTM A53M
14	Handle Bracket Bolt	Steel ASTM A193
15	Packing	PTFE ASTM D3294
16	Body Gasket	PTFE ASTM D3294
17	Seat Ring	RPTFE 15% GF ASTM D4894
18	Back Seat O-Ring	PTFE ASTM D3294
19	Handle Grip	Red Foam Rubber ASTM D 749
20	Body Cap	Cast Iron ASTM A126 Class B

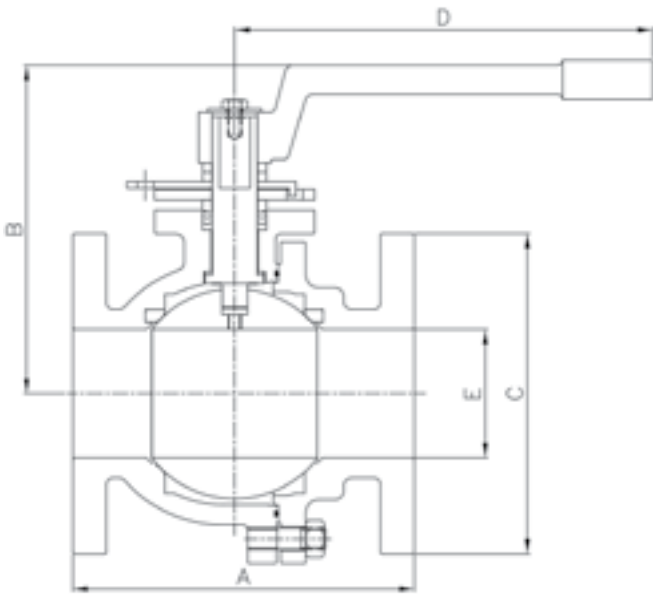

DIMENSIONS

	1/2"	3/4"	1"	1 1/2"	2"	2 1/2"	3"	4"	6"	8"	10"
A Face to Face	4.25"	4.625"	5"	6.5"	7"	7.5"	8"	9"	10.5"	11.5"	13"
B Center of Port to Top	4.25"	4.25"	4.75"	6"	6.5"	7.5"	8.25"	9"	12"	12.25"	13.5"
C Flange Diameter	3.5"	3.875"	4.25"	5"	6"	7"	7.5"	9"	11"	13.5"	16"
D Center of Valve to Handle End	11.875"	11.875"	11.875"	12.25"	12.5"	14"	14"	16"	30.5"	30.5"	33.625"
E Port Diameter	0.5"	0.75"	1"	1.5"	2"	2.5"	3"	4"	6"	6"	7.875"
Bolt Holes	4	4	4	4	4	4	4	8	8	8	12
Weight lbs.	6	7	10	17	24	43	50	77	149	190	309
CV	26	50	100	260	500	750	1245	2500	5470	4150	6700
Mounting Pad	-	-	-	F07	F07	F10	F10	F10	F12	F12	F12

SPECIFICATIONS

- A536 grade 65-45-12 ductile iron body
- PFA-fused solid stainless steel ball
- Blow-out proof stainless steel stem
- Reinforced PTFE seats
- Face to face and flanged dimensions conform to ANSI Standard B16.10 which exactly match end to end dimensions of carbon steel ball valves, ductile iron gate valves, and eccentric plug valves
- Lockable in full open or closed positions
- ISO mounting pad for easy actuation
- Adjustable length/removable handles to fit into areas of limited space
- Full port through 6"
- Certified to meet the requirements of:
 - NSF/ANSI/CAN 61 & 372
 - MSS SP-72
 - ANSI B16.10
 - FED. SPEC. WW-V-35
 - AWWA C507-99 (Proof of Design)
- This ductile iron ball valve has been engineered to replace any eccentric plug valve, carbon steel ball valve, or gate valve.

RATINGS

- 150 psi WSP
- 300 psi WOG
- 366° F



SAMPLE SPECIFICATION

Ball valves shall be of the floating-ball design providing bi-directional, tight shutoff in accordance with MSS SP-72. The valves shall be rated at 150# WSP/300# WOG. Bodies shall be ductile iron per ASTM A536, With ANSI Class 150 raised-face flanges. The interior and exterior of the body shall be powder coated and certified to NSF/ANSI/CAN standards 61 and 372. The ball shall be PFA infused stainless steel, with a stainless steel blowout-proof stem. The seats and body seals shall be PTFE. The stem seal shall be PTFE, externally adjustable chevron type. Valves shall be equipped with locking handles as standard. Valves may be equipped with 2" square operating nuts, manual gear operators, or pneumatic, electric, or hydraulic actuators. Valves shall be the 4000D Series as manufactured by American Valve, Inc. or as approved by the engineer.



Drawings
and
CAD files

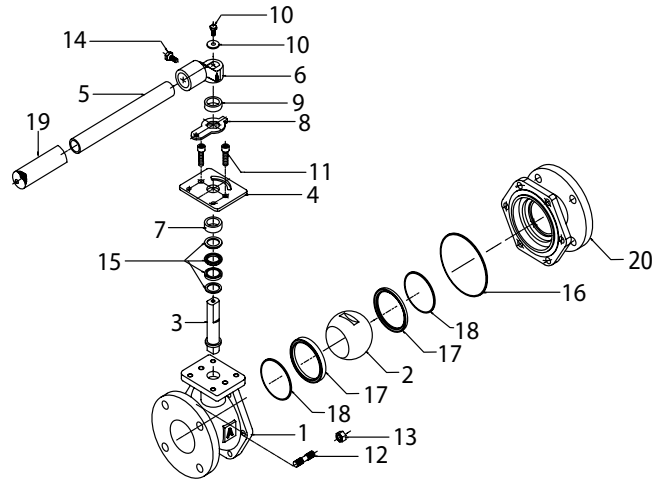

MATERIAL SPECIFICATIONS

	Part	Material	ASTM
1	Body	Ductile Iron	ASTM A536
2	PFA Fused Ball	Stainless Steel	ASTM A743 GR.CA 15
3	Stem	Stainless Steel	ASTM SA 479 -10a
4	Gland Plate	Steel	ASTM A53M
5	Handle	Steel	ASTM A53M
6	Handle Bracket	Ductile Iron	ASTM A536
7	Packing Follower	Stainless Steel	ASTM SA 479 -10a
8	Stem Indicator	Steel	ASTM A53M
9	Handle Bracket Spacer	Stainless Steel	ASTM SA 479 -10a
10	Stem Stud	Steel	ASTM A193
11	Gland Stud	Steel	ASTM A53M
12	Body Stud	Steel	ASTM A53M
13	Body Nut	Steel	ASTM A53M
14	Handle Bracket Bolt	Steel	ASTM A193
15	Packing	PTFE	ASTM D3294
16	Body Gasket	PTFE	ASTM D3294
17	Seat Ring	RPTFE 15% GF	ASTM D4894
18	Back Seat O-Ring	PTFE	ASTM D3294
19	Handle Grip	Red Foam Rubber	ASTM D 749
20	Body Cap	Ductile Iron	ASTM A536

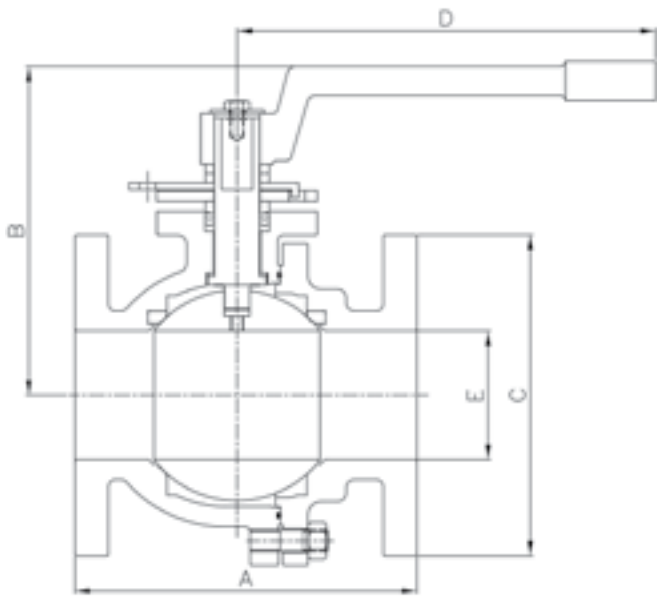

DIMENSIONS

	2"	2 1/2"	3"	4"	6"	8"	10"
A Face to Face	7"	7.5"	8"	9"	10.5"	11.5"	13"
B Center of Port to Top	6.5"	7.5"	8.25"	9"	12"	12.25"	13.5"
C Flange Diameter	6"	7"	7.5"	9"	11"	13.5"	16"
D Center of Valve to Handle End	12.5"	14"	14"	16"	30.5"	30.5"	33.625"
E Port Diameter	2"	2.5"	3"	4"	6"	6"	7.875"
Bolt Holes	4	4	4	8	8	8	12
Weight lbs.	25	42	55	78	149	194	318
CV	500	750	1245	2500	5470	4150	6700
Mounting Pad	F07	F10	F10	F10	F12	F12	F12

SPECIFICATIONS

- A536 Grade 65-45-12 Ductile Iron Body
- PFA-fused solid stainless steel ball
- Blow-out Proof Stainless Steel Stem
- Reinforced PTFE Seats
- Lockable in Full Open or Closed Positions
- Mounting Pad for Easy Actuation
- Adjustable Length/Removable Handles to fit into areas of limited space
- Full Port for unrestricted flow
- Certified to NSF/ANSI/CAN 61 & 372 for drinking water
- Grooved ends conform to AWWA C606 and are compatible with industry-standard grooved coupling systems

RATINGS

- 600 psi CWP
- 366° F



SAMPLE SPECIFICATION

Ball valves shall be of the floating-ball design providing bi-directional, tight shutoff in accordance with MSS SP-72. The valves shall be rated at 600 CWP. Bodies shall be ductile iron per ASTM A536, with grooved ends. The interior and exterior of the body shall be powder coated and certified to NSF/ANSI/CAN standards 61 and 372. The ball shall be PFA infused stainless steel, with a stainless steel blowout-proof stem. The seats and body seals shall be PTFE. The stem seal shall be PTFE, externally adjustable chevron type. Valves shall be equipped with locking handles as standard. Valves may be equipped with 2" square operating nuts, manual gear operators, or pneumatic, electric, or hydraulic actuators. Valves shall be the 4000DV Series as manufactured by American Valve, Inc. or as approved by the engineer.



Drawings
and
CAD files

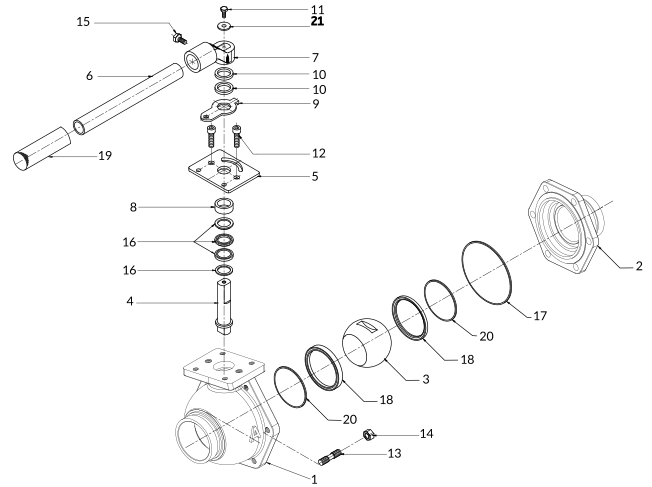

MATERIAL SPECIFICATIONS

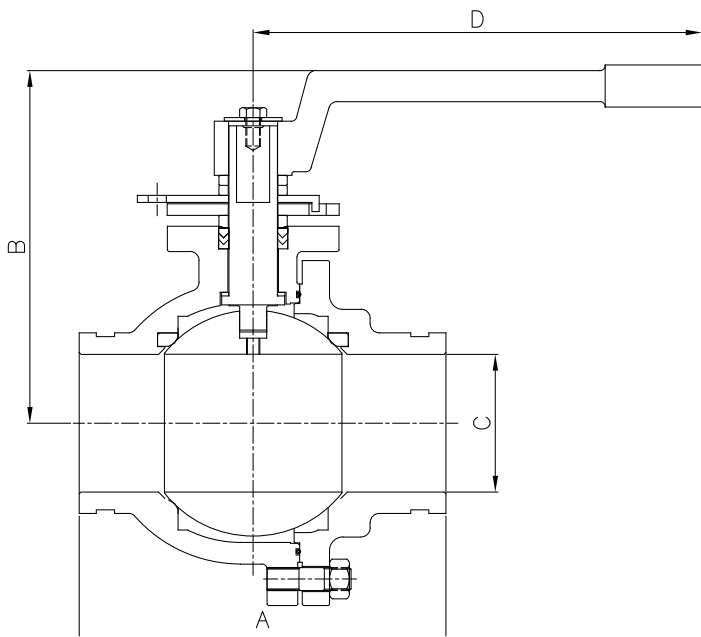

DIMENSIONS

Part	Material	ASTM
1	Body	Ductile Iron ASTM A536
2	Bonnet	Ductile Iron ASTM A536
3	PFA Fused Ball	AISI-410 ASTM A743 GR GA 15
4	Stem	Stainless Steel ASTM A479-410
5	Gland Plate	Steel ASTM A36
6	Handle	Steel ASTM A53M
7	Handle Bracket	Ductile Iron ASTM A536
8	Packing Follower	Stainless Steel ASTM A479-410
9	Stem Indicator	Steel ASTM A36
10	Handle Bracket Spacer	Stainless Steel ASTM A479-410
11	Stem Screw	Steel ASTM A194
12	Gland Screw	Steel ASTM A194
13	Body Stud	Steel ASTM A194-BB
14	Body Nut	Steel ASTM A193-BB
15	Handle Bracket Bolt	Steel ASTM A194
16	Packing	PTFE ASTM D3294
17	Body Gasket	PTFE ASTM D3294
18	Seat	RPTFE 15% GF ASTM D4894
19	Handle Grip	Red Foam Rubber ASTM D1056
20	Back Seat O-Ring	PTFE ASTM D3294
21	Washer	Steel ASTM A194

	2"	2 ½"	3"	4"	6"
A Face to Face	7"	7.5"	8"	9"	10.5"
B Center of Port to Top	6.5"	7.5"	8.25"	9"	12"
C Port Diameter	2"	2.5"	3"	4"	6"
D Center of Valve to Handle End	12.5"	14"	14"	16"	30.5"
Weight lbs.	16	35	47	68	122
CV	500	750	1245	2500	5470
Mounting Pad	F07	F10	F10	F10	F12

SPECIFICATIONS

- Cast 316 stainless steel (CF8M)
- PFA-fused solid stainless steel ball
- Blow-out proof stainless steel stem
- Reinforced PTFE seats
- Full port for unrestricted flow
- Lockable in full open or closed positions
- API 607 fire safe design
- Mounting pad for easy actuation
- Adjustable length/removable handles to fit into areas of limited space
- Certified to meet the requirements of:
 - NSF/ANSI/CAN 61 & 372
 - MSS SP-72
- This Stainless steel ball valve with PFA* fused ball has been engineered to more effectively resist corrosion and prolong valve life

RATINGS

- 150 psi WSP
- 300 psi WOG
- 366° F

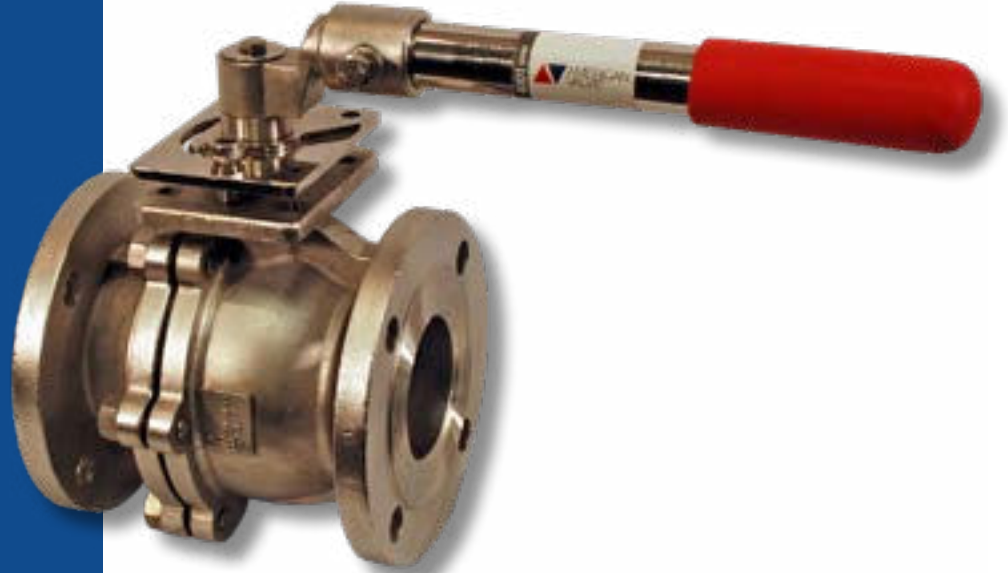

SAMPLE SPECIFICATION

Ball valves shall be full port and of the floating-ball design providing bi-directional, tight shutoff in accordance with MSS SP-72. The valves shall be rated at 150# WSP/300# WOG. Bodies shall be stainless steel per ASTM A351-CF8M, With ANSI Class 150 raised-face flanges. Valves shall be and certified to NSF/ANSI/CAN standards 61 and 372. The ball shall be PFA infused stainless steel, with a 316 stainless steel blowout-proof stem. The seats and body seals shall be PTFE. The stem seal shall be PTFE, externally adjustable chevron type. Valves shall be equipped with locking handles as standard. Valves may be equipped with 2" square operating nuts, manual gear operators, or pneumatic, electric, or hydraulic actuators. Valves shall be the Series 4001 as manufactured by American Valve, Inc. or as approved by the engineer.



Drawings
and
CAD files

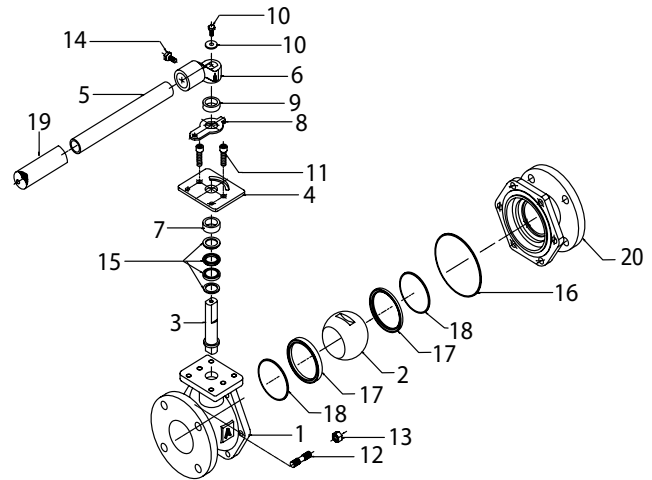
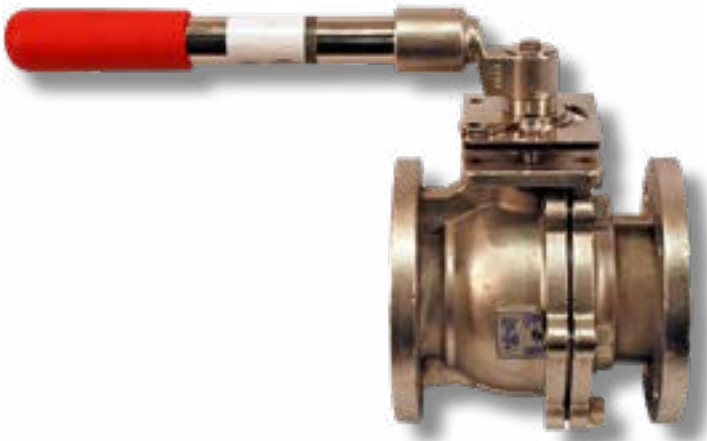

MATERIAL SPECIFICATIONS

Part	Material	ASTM
1	Body	Stainless Steel ASTM A351-CF8M
2	PFA Fused Ball	Stainless Steel ASTM A351-CF8M
3	Stem	Stainless Steel ASTM A276-316
4	Gland Plate	Stainless Steel ASTM A479-11
5	Handle	Stainless Steel ASTM A312
6	Handle Bracket	Stainless Steel ASTM A351 CF8
7	Packing Follower	Stainless Steel ASTM A276-316
8	Stem Indicator	Stainless Steel ASTM A479-11
9	Handle Bracket Spacer	Stainless Steel ASTM A276-316
10	Stem Stud	Stainless Steel ASTM 0193-B8
11	Gland Stud	Stainless Steel ASTM 0193-B8
12	Body Stud	Stainless Steel ASTM 0193-B8
13	Body Nut	Stainless Steel ASTM 0193-B8
14	Handle Bracket Bolt	Stainless Steel ASTM 0193-B8
15	Packing	PTFE ASTM D3294
16	Body Gasket	PTFE ASTM D3294
17	Seat Ring	RPTFE 15% GF ASTM D4894
18	Back Seat O-Ring	PTFE ASTM D3294
19	Handle Grip	Red Foam Rubber ASTM D 749
20	Body Cap	Stainless Steel ASTM A351-CF8M

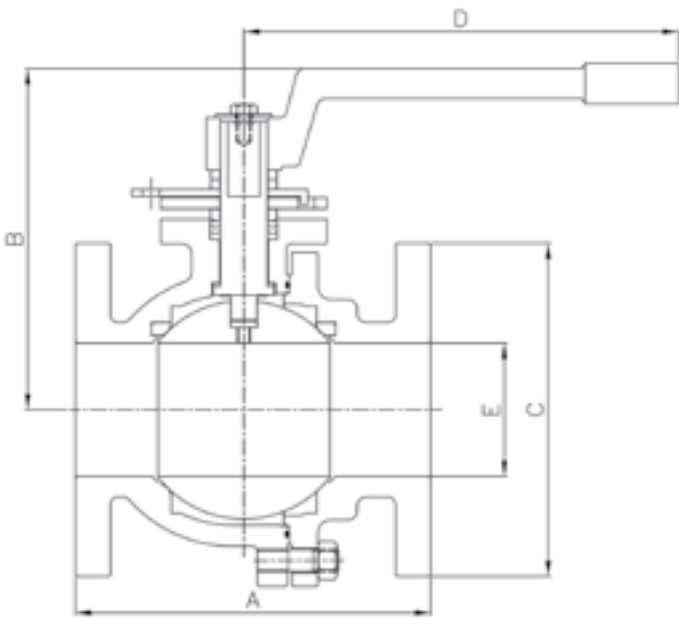

DIMENSIONS

	1 ½"	2"	2 ½"	3"	4"	6"
A Face to Face	6.5"	7"	7.5"	8"	9"	10.5"
B Center of Port to Top	6"	6.5"	7.5"	8.25"	9"	12"
C Flange Diameter	5"	6"	7"	7.5"	9"	11"
D Center of Valve to Handle End	12.25"	12.25"	14"	14"	16"	30.5"
E Port Diameter	1.5"	2"	2.5"	3"	4"	6"
Bolt Holes	4	4	4	4	8	8
Weight lbs.	16	22	38	49	73	145
CV	260	500	750	1245	2500	5470
Mounting Pad	F07	F07	F10	F10	F10	F12

SPECIFICATIONS

- PFA-fused solid ball
- Same end-to-end as any flanged gate or plug valve
- Tapped and plugged boss allows for venting downstream, or test port for backflow preventer
- Full port for unrestricted flow
- Class VI positive shutoff
- Low torque
- Ideal for liquid, air, and backflow applications
- Certified to NSF/ANSI/CAN 61 & 372 for drinking water
- This cast iron ball valve has been engineered to replace any IBBM gate valve, all-iron gate valve, or plug valve

RATINGS

- 200 W @ 200° F



SAMPLE SPECIFICATION

Ball valves shall be of the floating-ball design providing bi-directional, tight shutoff in accordance with MSS SP-72. The valves shall be rated 200 psi non-shock at 200deg F. Bodies shall be of cast iron per ASTM A126 Class B, with ANSI Class 125 flat-face flanges. The interior and exterior of the body shall be powder coated and certified to NSF/ANSI/CAN standards 61 and 372. The ball shall be PFA infused cast iron, with a stainless steel blowout-proof stem. The seats shall be PTFE and body O-ring Buna-N. Valves shall be equipped with locking handles and one test port as standard. Valves may be equipped with 2" square operating nuts. Valves shall be the Series 3700 as manufactured by American Valve, Inc. or as approved by the engineer.



C US

Certified to NSF/ANSI/CAN
Standards 61 & 372

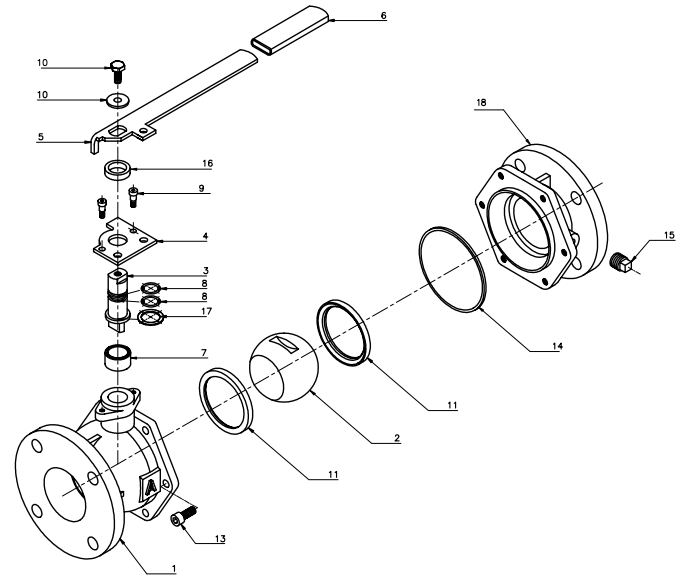

MATERIAL SPECIFICATIONS

Part	Material	
1	Body	Cast Iron/ASTM A126 Class B
2	Ball	Cast Iron/PFA Fused ASTM A48 Class-35
3	Stem	Stainless Steel
4	Stop Plate	Steel
5	Handle	Steel
6	Handle Grip	Vinyl Dipped Platisol
7	Sleeve	Stainless Steel
8	Stem O-Ring	Nitrile Rubber (Buna-N)
9	Shoulder Screw	Steel
10	Stem Bolt/Washer	Steel
11	Seat Ring	RPTFE 15% GF
13	Socket Head Screw	Steel
14	Body Gasket	Nitrile Rubber (Buna-N)
15	Body Plug	2" - 4": Steel 6" - 8": Cast Iron
16	Collar	Steel
17	Thrust Washer	PTFE
18	Body Cap	Cast Iron/A126 Class B
19	Handle Grip	Red Foam Rubber
20	Body Cap	Cast Iron

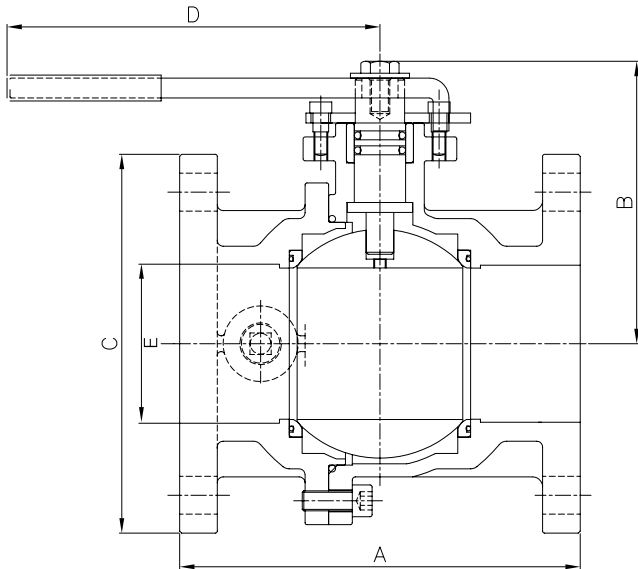

DIMENSIONS

	2"	2 ½"	3"	4"	6"	8"
A Face to Face	7.00"	7.50"	8.00"	9.00"	10.50"	11.50"
B Center of Port to Top	5.50"	5.22"	5.59"	6.34"	8.31"	9.76"
C Flange Diameter	6.00"	7.00"	7.50"	9.00"	11.00"	13.500"
D Center of Valve to Handle End	12.00"	10.20"	10.90"	12.60"	16.70"	19.70"
E Port Diameter	2.00"	2.50"	3.00"	4.00"	6.00"	8.00"
Bolt Holes	4	4	4	8	8	8
Weight (lbs.)	25	30	38	62	118	199
Pallet Quantity	60	60	48	24	12	8

SPECIFICATIONS

- PFA-fused solid ball
- Double tapped and plugged bosses allow for venting or draining downstream, or test port for backflow preventer
- Full port for unrestricted flow
- Class VI positive shutoff
- Low torque
- Ideal for liquid, air, and backflow applications
- Certified to NSF/ANSI/CAN 61 & 372 for drinking water
- Grooved ends conform to AWWA C606 and are compatible with industry-standard grooved coupling systems

RATINGS

- 200 W @ 200° F



SAMPLE SPECIFICATION

Ball valves shall be of the floating-ball design providing bi-directional, tight shutoff in accordance with MSS SP-72. The valves shall be rated 200 psi non-shock at 200deg F. Bodies shall be of cast iron per ASTM A126 Class B, with grooved ends. The interior and exterior of the body shall be powder coated and certified to NSF/ANSI/CAN standards 61 and 372. infused cast iron, with a stainless steel blowout-proof stem. The seats shall be PTFE and body O-ring Buna-N. Valves shall be equipped with locking handles and test ports as standard. Valves may be equipped with 2" square operating nuts. Valves shall be the Series 3700V as manufactured by American Valve, Inc. or as approved by the engineer.



C US

Certified to NSF/ANSI/CAN
Standards 61 & 372

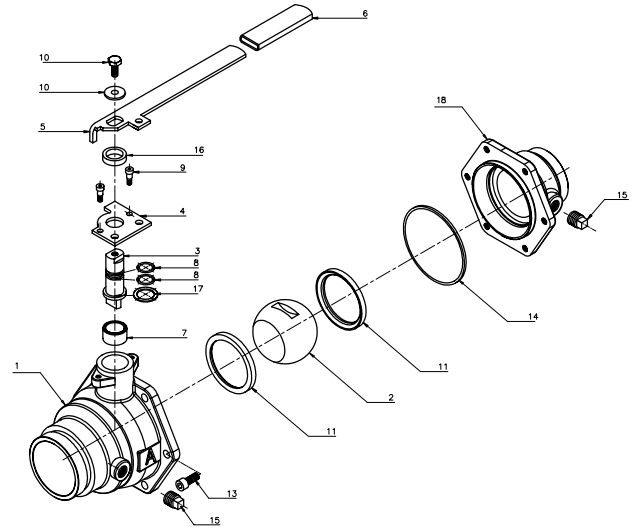

MATERIAL SPECIFICATIONS

Part	Material
1 Body	Cast Iron/ASTM A126 Class B
2 Ball	Cast Iron/PFA Fused ASTM A48 Class-35
3 Stem	Stainless Steel
4 Stop Plate	Steel
5 Handle	Steel
6 Handle Grip	Vinyl Dipped Plastisol
7 Sleeve	Stainless Steel
8 Stem O-Ring	Nitrile Rubber (Buna-N)
9 Shoulder Screw	Steel
10 Stem Bolt/Washer	Steel
11 Seat	RPTFE 15% GF
13 Socket Head Screw	Steel
14 Body Gasket	Nitrile Rubber (Buna-N)
15 Body Plug	2" - 4": Steel 6": Cast Iron
16 Collar	Steel
17 Thrust Washer	PTFE
18 Body Cap	Cast Iron/A48 Class 30

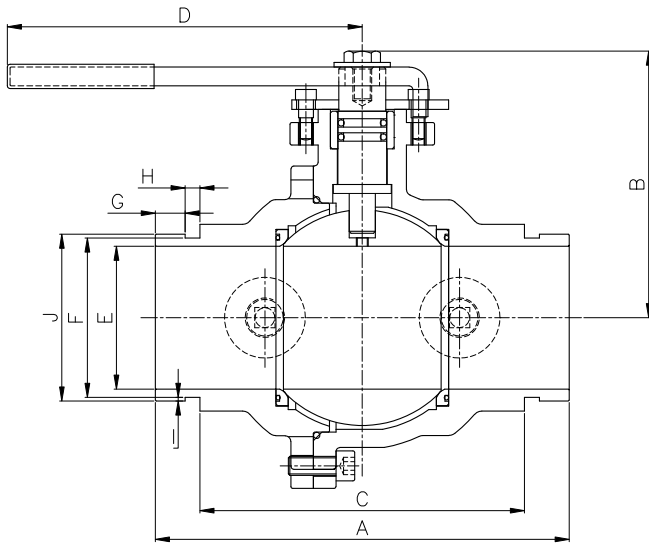

DIMENSIONS

	2"	2 ½"	3"	4"	6"
A End to End	7.80"	8.64"	8.68"	9.90"	12.56"
B Center of Port to Top	4.37"	5.31"	5.59"	6.34"	8.31"
C Face to Face	5.80"	6.77"	6.81"	7.90"	10.56"
D Center of Valve to Handle End	9.29"	9.76"	9.76"	10.67"	16.79"
E Port Diameter	2.00"	2.50"	3.00"	4.00"	6.00"
F Groove Diameter	2.24"	2.72"	3.34"	4.33"	6.45"
G Gasket Seat	0.63"	0.63"	0.63"	0.63"	0.63"
H Groove Width	0.31"	0.31"	0.31"	0.37"	0.38"
I Groove Depth	0.06"	0.08"	0.08"	0.08"	0.09"
J Grooved End OD	2.37"	2.87"	3.50"	4.5"	6.63"
Weight (lbs.)	12	19	26	45	105
Pallet Quantity	60	60	48	24	12

	Minimum Tensile Strength	Minimum Yield Point	Minimum Elongation
Grey Iron A126 Class B	31,000 psi	---	0.1%
Ductile Iron A536 Grade 65-45-12	65,000 psi	45,000 psi	12%
Carbon Steel A216 WCB	70,000 psi	30,000 psi	22%
304 Stainless Steel A-351 CF8	70,000 psi	28,000 psi	35%
316 Stainless Steel A-351 CF8M	70,000 psi	30,000 psi	30%

	Grey Iron	65-45-12 Ductile Iron	WCB	CF8	CF8M
Carbon % (max.)	3.500	3.500	0.300	0.080	0.080
Manganese %	0.500	0.100	1.000	1.500	1.500
Phosphorous %	0.100	0.030	0.040	0.040	0.040
Sulfur %	0.100	0.005	0.050	0.040	0.040
Nickel %	0.020	0.000	0.500	8.000	9.000
Chromium %	0.050	0.025	0.040	18-21	18-21
Molybdenum %	0.05	0.002	0.250	-	2-3
Silicon %	2.100	3.200	0.300	2.000	2.000
Magnesium %	0.005	0.025	-	-	-

Model 4000 is made of cast iron (ASTM A126 Class B, standard gray iron). Model 4000D is made of ductile iron (ASTM 536, grade 65-45-12). Model 4001 is made of stainless steel (ASTM A351 CF8M).

It is useful to understand basic information about ferrous metals (cast irons, steels) and their relationships. 100% pure iron is never used as a cast metal because it is too soft and weak. When carbon is added, hardness and strength appear. When approximately 0.3% carbon is added, the resulting alloy is steel. Steel is a strong but difficult ferrous metal to manufacture from a production standpoint. Adding more carbon (up to about 2%) creates even more production problems. These “semi-steels” are seldom used.

When more carbon is added (between 2% and 3%), white iron is formed. White iron is true cast iron and is easy to produce. The problem with white iron is that it is very brittle because the carbon exists as iron carbide instead of pure carbon. Iron carbide (Fe₃C) is a hard and brittle compound sometimes referred to as cementite. If white iron is subjected to a lengthy heat treatment, the Fe₃C decomposes into iron and nodules of graphite. The end product is malleable iron.

When approximately 3.5% carbon is added, Fe₃C exceeds its solubility in solid iron (the Fe₃C is fully absorbed in the iron until there is no room left. The excess Fe₃C is dispersed as graphite flakes). The result is gray iron. Grey iron (standard cast iron) delivers only moderate strength with almost no elongation because the excess Fe₃C flakes act as stress raisers (they make cast iron easy to crack). Since gray iron is so economical to produce, its use has been widespread for centuries.

Cast Iron with spheroidal graphite (ductile iron) was first produced in 1948. Its chemical composition and percent of carbon is about the same as gray iron. The transformation to ductile iron occurs when molten gray iron is treated with magnesium. The insertion of magnesium into the pouring ladle (the process is called inoculation) transforms the Fe₃C flakes into spheroids. These spheroids strengthen the metal by acting as crack arresters instead of crack facilitators. Ductile iron is sometimes referred to as spheroidal or nodular iron.

65-45-12 ductile iron is named for its physical properties (65,000 psi tensile strength, 45,000 psi yield, 12% elongation). Ductile iron chemically can be manufactured as Ferritic or Pearlitic. In Ferritic mixes, the graphite spheroids are in a matrix of pure iron. In Pearlitic mixes, the graphite spheroids are in a matrix of pure iron and cementite (Fe₃C). The most common grade of ductile is Pearlitic-Ferritic, a combination of the two. American Valve’s 4000D uses a predominately Ferritic mix (9:1) to take advantage of its high impact resistance and added tensile strength (80,000 psi).

Except where API 800° F fire safe standards are required for petrochemical refineries, ductile iron is generally preferable to a carbon steel because WCB has a tendency to flake, whereas ductile iron powders when subjected to liquid erosion. Ductile iron also possesses 50% higher yield strength properties and is more cost effective. Ductile iron castings have a maximum temperature rating of 650° F. Traditional glass reinforced PTFE seats begin to deform at 360° F.

ASTM A536-70 (MIL SPEC D-4512) requires each casting to be marked by its foundry heat number. Each heat is chemically tested prior to magnesium inoculation and also afterwards. Chemical certification by heat number is available upon request.

Standard cast steel (carbon steel) uses the symbol WCB and is defined under ASTM A-216. It contains a maximum of 0.3% carbon.

Stainless steel (ASTM A-351) has carbon levels even lower than WCB (0.08% maximum) making its production more costly. 304 Stainless Steel (CF8) adds 8% nickel, about 20% chromium, and a little more silicon. 316 stainless steel (CF8M) adds 2-3% molybdenum to the above. The addition of chromium, nickel and molybdenum enhances corrosion resistance, allowing CF8M to be utilized in a wide variety of chemical, petrochemical, and corrosive environments.



OPERATING TORQUES

The actual amount of torque required to operate a valve is dependent upon many variables, such as line pressure, temperature, type of fluid, and frequency of operation. This table is based on average breakaway torque requirements for a valve handling a clean, particle-free liquid such as water. The following chart includes a safety allowance for service conditions. The torque figures listed should be further adjusted for dry or special service conditions.

For fluids with high solids or abrasive content, consult factory for recommendations.

Size	Torque (ft. lbs.)
½"	10
¾"	10
1"	10
1 ½"	20
2"	35
2 ½"	48
3"	62
4"	130
6"	260
8"	360
10"	535

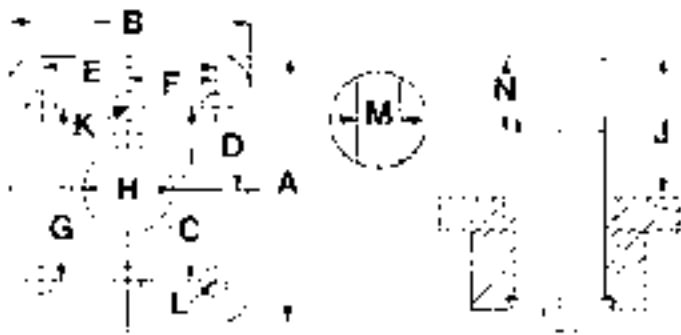

MOUNTING PAD DIMENSIONS

Size	A	B	C	D	E	F	G	H	J	K	L	M	N
½	2.37	1.75	1.565	0.57	1.14	0.57	1.14	0.5	1.5	2 x M8	4 x .25UNC	0.31	0.67
¾	2.37	1.75	1.565	0.57	1.14	0.57	1.14	0.5	1.5	2 x M8	4 x .25UNC	0.31	0.67
1	2.37	1.75	1.565	0.57	1.14	0.57	1.14	0.5	1.5	2 x M8	4 x .25UNC	0.31	0.67
1 ½	3.62	2.746	2.323	0.985	1.97	0.985	1.97	0.825	2.1	2 x M12	4 x M8	0.47	1.495
2	3.62	2.746	2.323	0.985	1.97	0.985	1.97	0.825	2.1	2 x M12	4 x M8	0.47	1.495
2 ½	4.725	3.74	2.957	1.418	2.835	1.418	2.835	1.1	2.4	2 x M12	4 x M10	0.665	1.81
3	4.725	3.74	2.957	1.418	2.835	1.418	2.835	1.1	2.4	2 x M12	4 x M10	0.665	1.81
4	4.725	3.74	2.957	1.418	2.835	1.418	2.835	1.1	2.4	2 x M12	4 x M10	0.665	1.81
6	5.16	4.725	3.465	1.733	3.465	1.733	3.465	1.775	2.75	2 x .5UNC	4 x M12	1.06	2.205
8	5.16	4.725	3.465	1.733	3.465	1.733	3.465	1.775	2.75	2 x .5UNC	4 x M12	1.06	2.205
10	5.16	4.725	3.465	1.733	3.465	1.733	3.465	1.775	2.75	2 x .5UNC	4 x M12	1.06	2.205

Dimensions and weights are given as approximates; consult factory for details.

MORE THAN JUST A VALVE

American Valve offers a complete package of pneumatic, hydraulic and electric actuators, gear operators, and operating nuts for the 4000 Series. Our unique PFA-fused ball and lower operating torques make the 4000 Series an effective alternative to cast iron gates, carbon steel ball valves, carbon steel gate valves, and plug valves. Our in-house automation service provides a fast, cost-effective, and turn-key solution for your automation needs.

Pneumatic, hydraulic and electric actuators made for the 4000 Series have an unmatched cycle life and are the industry-wide preference for even the most severe applications. These actuators offer adaptability to a variety of process conditions to accommodate your application.

The flexible, modular design of the patented 4000 Series can be used to combine actuators, solenoid valves, limit switches, and other accessories in a variety of applications. American Valve delivers the 4000 Series fully automated and factory tested under a single manufacturer's warranty.

Standard 2" square operating nuts are available to effectively satisfy underground requirements.



4000 SERIES VS. GATE VALVES

- Quarter turn provides instant shutoff.
- Full unobstructed opening provides superior flow rate.
- Easy to open and close, no cheater bar required.
- Class VI positive shutoff.
- No bronze seat rings, bronze disc rings or bronze stems to wear out.
- Lighter than gate valves, making installation and handling easier.
- Handle shows whether open or closed.
- Ball wipes clean during opening and closing.
- No bronze parts enables use in all-iron gate valve applications.
- Compact design fits into areas of limited space.
- Throttling is permitted. Open and shut are not the only working positions.
- Easier to store and ship
- Can be locked in either open or closed position.
- Zero wear rate in the open position.
- Easy and inexpensive to rebuild/repair.

4000 SERIES VS. BUTTERFLY VALVES

- No disc in waterway to create turbulence.
- Reinforced PTFE seats, not Buna N or EPDM.
- More suitable for steam, petroleum, and corrosive applications.
- Main seating surface does not face upstream pressure in open position.
- Full opening provides superior flow characteristics.
- PTFE packing instead of O-ring stem seals.
- Class VI positive shutoff.
- Blow-out proof stainless steel stem.

4000 SERIES VS. ECCENTRIC PLUG VALVES

- Full unobstructed flow.
- No exposed internal components to catch and retain debris.
- No lubrication required to ensure smooth operation and maintain seals.
- Lower torque for more efficient and cost effective automation.
- Class VI positive shutoff.



sales@americanvalve.com
Tel. 1.800.645.0101



@AmericanValve