



P.O. Box 35229
Greensboro, NC 27425
1-800-645-0101
or (336) 668-0554
fax: 1-800-876-0109
or (336) 668-4070



American Valve Butterfly Valves are manufactured in accordance with the specifications from MSS SP-67, Manufacturers Standardization Society and API-609, American Petroleum Institute Latest Revisions. Both Lug and Wafer series valves are designed for ANSI B1 16.5 125/150 Lb. class flanges and are rated at 200 PSI WOG service.

American Series 7000 Butterfly Valves are 100% factory tested in both directions of operation to assure a Zero leakage rate for many years of BubbleTite service.

American Series 7000 Butterfly Valves make an excellent choice by combining the balance of an economical valve with the performance required for Commercial, HVAC and Industrial applications.

American Series 7000 Butterfly Valves are available with many options and accessories needed for the typical butterfly valve application.

American Valve Series 7000 Butterfly Valves

- **Disc materials:** Ni Coated Ductile Iron, Bronze, 316SS.
- **Seat materials:** Buna-N, EPDM, Viton & Specials.
- **10 Position Handle, Infinite Position and Gear Operators.**
- **Electric Motor Operators.**
- **Pneumatic Cylinder Operators.**
- **Galvanized Stem Extensions (Extended Bonnets).**
- **Chain Wheel Operators, Square Operating Nuts and Cranks.**
- **100% Bi-directional factory tested.**
- **Extended neck design for ample application of insulation.**
- **One piece/uni-body construction to accommodate both ANSI and DIN flanges.**
- **Integral mounting flange will accept all styles of gear operators and actuators.**
- **Oil impregnated stem bushings assure long life even during extended periods of inactivity.**
- **One piece resilient seat with integral o-ring eliminates the need for additional flange gaskets.**
- **Integral o-ring seals for upper and lower valve shafts work with disc edge hub seals to provide a double stem seal.**
- **Two piece shaft design eliminates the need for bolts or pins to attach shaft to disc, thereby removing potential leak path of media. Two piece shaft design allows for a reduction in disc thickness thus creating less obstruction in waterway which results in lower Cv factors.**
- **Suitable for open left or open right operation.**
- **Field change over and field replaceable seats are standard design features.**
- **“Tangential” pin for mechanical stem retention standard.**

LUG



P.O. Box 35229
Greensboro, NC 27425
1-800-645-0101
or (336) 668-0554
fax: 1-800-876-0109
or (336) 668-4070

Specifications:

MSS SP-67
API-609

Rating

200 WOG

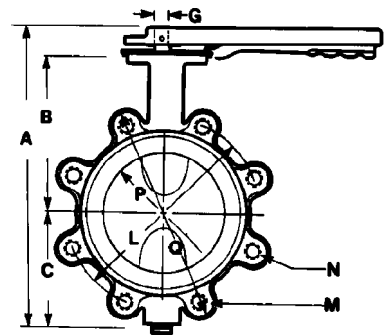
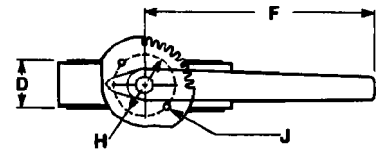

	Disc	Stem	Seat Material	Body Style
7000L	Ni Plated Ductile	416SS	Buna N	Lug
7001L	Ni Plated Ductile	41 6SS	EPDM	Lug
7100L	Bronze	416SS	Buna N	Lug
7101L	Bronze	416SS	EPDM	Lug
7210L	316SS	316SS	Buna N	Lug
7211L	316SS	316SS	EPDM	Lug

Dimension Table (inches)

SIZE	2	2 1/2	3	4	5	6	8	10	12
A	9 3/8	10 3/16	10 11/16	13	14	15 3/16	17 3/4	20 1/2	23 1/2
B	5 3/8	5 15/16	6	7	7 9/16	7 15/16	9 3/16	10 1/2	12 1/16
C	3	3 1/4	3 11/16	4 13/16	5 1/4	5 7/8	6 15/16	8 3/8	9 13/16
D	1 3/4	1 7/8	1 7/8	2 1/8	2 1/4	2 1/4	2 1/2	2 13/16	3 1/8
F	8	8	8	11	11	11	16	16	16
G	.561	.561	.561	.686	.686	.811	.936	1.123	1.247
H	3 1/4	3 1/4	3 1/4	3 1/4	3 1/4	3 1/4	4 3/4	4 3/4	4 3/4
J	.266	.266	.266	.266	.266	.266	.563	.563	.563
L	4 3/4	5 1/2	6	7 1/2	8 1/2	9 1/2	11 3/4	14 1/4	17
*M	5/8-11	5/8-11	5/8-11	5/8-11	3/4-10	3/4-10	3/4-10	7/8-9	7/8-9
THREAD	UNC	UNC	UNC	UNC	UNC	UNC	UNC	UNC	UNC
**N	4	4	4	8	8	8	8	12	12
P	2	2 1/2	3	4	5	6	8	10	12
Q	6	7	7 1/2	9	10	11	13 1/2	16	19

*M - Tap Size

**N - Number of Holes

The Lug configuration is tapped in accordance with ANSI B1.1 course thread series, Class B through all sizes



WAFER

Specifications:
MSS SP-67
API-609

Rating:
200 WOG



P.O. Box 35229
Greensboro, NC 27425
1-800-645-0101
or (336) 668-0554
fax: 1-800-876-0109
or (336) 668-4070

	Disc	Stem	Seat Material	Body Style
7000W	NI Plated Ductile	416SS	Buna N	Wafer
7001W	NI Plated Ductile	416SS	EPDM	Wafer
7100W	Bronze	416SS	Buna N	Wafer
7101W	Bronze	416SS	EPDM	Wafer
7210W	316SS	316SS	Buna N	Wafer
7211W	316SS	316SS	EPDM	Wafer

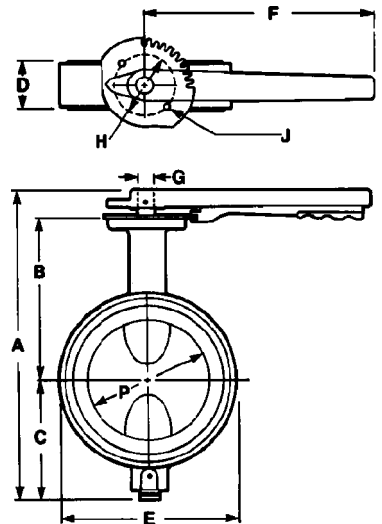

Dimension Table (inches)

SIZE	2	2 1/2	3	4	5	6	8	10	12
A	9 3/8	10 3/16	10 11/16	13	14	15 3/16	17 3/4	20 1/2	23 1/2
B	5 3/8	5 15/16	6	7	7 9/16	7 15/16	9 3/16	10 1/2	12 1/16
C	3	3 1/4	3 11/16	4 13/16	5 1/4	5 7/8	6 15/16	8 3/8	9 13/16
D	1 3/4	1 7/8	1 7/8	2 1/8	2 1/4	2 1/4	2 1/2	2 13/16	3 1/8
E	4	4 3/4	5 1/4	6 1/8	7 1/2	8 1/2	10 5/8	12 1/2	14 3/4
F	8	8	8	11	11	11	16	16	16
G	.561	.561	.561	.686	.686	.811	.936	1.123	1.247
H	3 1/4	3 1/4	3 1/4	3 1/4	3 1/4	3 1/4	4 3/4	4 3/4	4 3/4
J	.266	.266	.266	.266	.266	.266	.563	.563	.563
P	2	2 1/2	3	4	5	6	8	10	12

#	ITEM DESCRIPTION	MATERIAL SPECIFICATION	QTY
1	Body Lug/Wafer Cast Iron	ASTMA-126-B	1
2	Liner - Buna N	ASTM D-2000	1
	Liner - EPDM	ASTM D-2000	1
	Liner - VITON	ASTM D-2000	1
3	Disc - Bronze	ASTM B-62	1
	Disc - Ni Coated Ductile Iron	ASTMA-395 (60-40-18)	1
	Disc - 316 SS	ASTMA-351 Grade CF8M	1
4	Upper Stem 416 SS	ASTMA-582	1
	Upper Stem 316 SS	ASTMA-479	1
5	Lower Stem 416 SS	ASTMA-582	1
	Lower Stem 316 SS	ASTMA-479	1
6	Upper Stem Bearing	Oil Impregnated Bronze	1
7	Upper Stem O-Ring	Buna N or EPDM or Viton	1
9	Upper Stem O Ring	Buna N or EPDM or Viton	1
10	Lower Stem Set Screw	ASTMA-582	1
12	Position Plate 10 Pos./Inf. Pos.	Carbon Steel	1
13	Lock Washer	Carbon Steel (Cad Plated)	2
14	Hex Nut	Carbon Steel (Cad Plated)	2
15	Hex Head Bolt	Carbon Steel (Cad Plated)	2
16	Tangential Retaining Pin	Carbon Steel	1

Specifications:

MSS SP-67
API-609
200 psi WOG

Bill of Material List

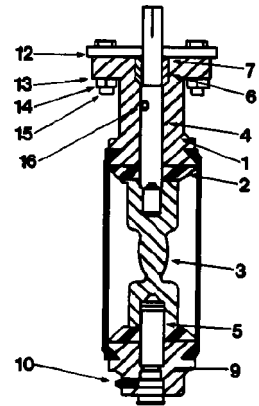

Approximate Operating Torque (inch pounds)

SIZE	0 PSI		100 PSI		200 PSI	
	WET	DRY	WET	DRY	WET	DRY
2	130	175	160	220	190	250
2 1/2	150	200	190	250	225	300
3	200	275	260	350	300	400
4	330	450	420	550	450	600
5	375	500	620	825	675	900
6	675	900	900	1200	1100	1450
8	900	1200	1200	1600	1500	2000
10	1900	2500	2250	3000	2900	3800
12	2400	3200	3400	4500	4500	6000

Use these seating torques only as an estimating guide for actuator sizing. Any variations in the media condition will affect the operating torque.

	2	2 1/2	3	4	5	6	8	10	12
100% Open	130	190	360	650	1400	1900	3300	5000	7500
33% Open	14	21	39	71	154	209	363	550	825
16 FPS @ Full Open	157	245	353	628	982	1413	2512	3925	5625
4 FPS @ Full Open	40	61	88	157	245	353	628	990	1413

Flow in Gallons Per Minute

"Cv Factors"

A valve's flow characteristic is generally described as its Cv factor. Cv is defined as the flow in GPM (Gallons Per Minute) that will produce a 1 pound pressure drop across the valve.

Typically Butterfly Valves (other than high performance) are made up of two classes. Class A, designed for 8 FPS (Feet Per Second), or Class B, designed for 16 FPS. It is recommended that all applications be sized using 16 FPS or less. While Butterfly Valves will allow flow much greater than 16 FPS, this velocity assures that the valve installation and its piping system will give many years of satisfactory service. It is also recommended that no Butterfly Valve be installed in a throttling application where the valve will be open less than 33% or less than 30 degrees. It is further recommended that no obstruction, equipment or pipeline deviation be installed closer than 8 times the pipe diameter downstream of the valve installation. This allows for flow stabilization in the piping system, thus eliminating potential erosion or cavitation.

SERIES 7000	2	2 1/2	3	4	5	6	8	10	12
Wafer style with handle	7	9	10	14	18	22	39	64	99
Wafer style with gear operator	11	13	14	18	22	26	44	69	104
Lug style with handle	9	10	11	20	24	28	47	98	117
Lug style with gear operator	13	14	15	24	28	32	52	103	122

Shipping Weights



P.O. Box 35229
Greensboro, NC 27425
1-800-645-0101
or (336) 668-0554
fax: 1-800-876-0109
or (336) 668-4070

Reference Information

	Disc	Stem	Seat Material	Body Style
7000W	NI Plated Ductile	416SS	Buna N	Wafer
7001W	NI Plated Ductile	416SS	EPDM	Wafer
7000L	NI Plated Ductile	416SS	Buna	Lug
7001L	NI Plated Ductile	416SS	EPDM	Lug
7100W	Bronze	416SS	Buna N	Wafer
7101W	Bronze	416SS	EPDM	Wafer
7100L	Bronze	416SS	Buna N	Lug
7101L	Bronze	416SS	EPDM	Lug
7210W	316SS	316SS	Buna N	Wafer
7211W	316SS	316SS	EPDM	Wafer
7210L	316SS	316SS	Buna N	Lug
7211L	316SS	316SS	EPDM	Lug

AMERICAN SERIES 7000	7000W	7000L	7001W	7001L	7100W
Centerline	Series A	Series LT	Series A	Series LT	Series A
Crane	21/22N FRB	23/24N FRB	21/22N-FRZ	23/24N-FRZ	12F-TL
Demco	NL 111535	NE 511531	NE-111536	NE-511531	NE-111435
Dezurik	632W/660W	632L/660L	632W/660W	632L/660L	632W/660W
Grinnel	WD-8191	LD 8191	WD-8291	LD-8291	WC-8181
Hammond	6100	6200	6101	6201	6110
Keystone	100	122/129	100/239	1 22/129	100/239
Milwaukee	MW122B	ML1722B	MW122E	ML122E	ML123B
Mueller	51-ANI-3	52-ANI-3	51-ANI 6	52-ANI-6	51 -ANK-3
Nibco	WD-3110	LD-3110	WD-3010	LD-3010	WD2100
Norris	R-1011	R 3011	R 1011	R-3011	R-1011
Stockham	LD-511-DS3-B	LD-711-DS3-B	LD-511-DS3-E	LD 711-DS3-E	LD 511-BS3-B
Watts	BF-04-111-2	BF-03-111-2	BF 04-111-1	BF 03-111-1	BF-04-121-2

AMERICAN SERIES 7000	7100L	7101W	7101L	7111W	7211L
Centerline	Series LT	Series A	Series LT	Series A	Series LT
Crane	14W-TL	12F-TL	14W-TL	44N-SSZ	42N-SSZ
Demco	NE-511431	NE-111435	NE-511431	NE-112235	NE-51/2231
Dezurik	632L/660L	632W/660W	632L/660L	632W/660W	632L/660L
Grinnel	LC-8181	WC-8181	LC-8281	LD 8271	WD 8271
Hammond	6210	6111	6211	6121	6221
Keystone	122/129	100/239	129/122/228	100	122
Milwaukee	ML1238	MW123E	ML123E	MW124E	ML124E
Mueller	52-ANK-3	51-ANK-6	52-ANK-6	51H-AHH 6	52-AHH 6
Nibco	LD-2100	WD-2000	LD-2000	WD-3022	LD 3022
Norris	R-3011	R-1011	R 3011	R 1011	R-3011
Stockham	LD 711 BS3-B	LD-511-BS3-E	LD-711-BS3-E	LD-511-SS2 E	LD -711-SS2E
Watts	BF-03-121-2	BF-04-12-12	BF-03-121-1	BF-04-131-1	BF-03-131-1